

Ref. : VG 3400-01.pas

Rev. : I

Date :23/05/2012

Page : 1/1

KNIFE GATE VALVE WITH CHAIN HANDWHEEL CAST IRON BODY VG 3400-01



APPLICATION

General use : Pulp production, water, water treatment, waste water, chemical industry (powdery or crystallizing products), wine-producing, pulverized products (cement work, pneumatic transport, stocking).

GENERAL CHARACTERISTICS

Range : from DN 50 to DN 600.
Function ON/OFF or regulation.
Wafer threaded mounting ISO PN10.
Unidirectional tightness, direction indication thanks to the arrow on the body.
Small retention zone: the gate is guided in the body and has little clearance.
Gland assembly: packing and O-ring (same materials as seat joint) to assure the elasticity and decrease the operating torque. Small head loss. Possibility to regulate thick fluids with the adaptation of a diaphragm ring.

CONSTRUCTION

17**	1	Support ring	Stainless steel 316	DIN: X5CrNi18 10 ASTM: A 182 AISI 304 BS: 1449-2 304 S15
16	1	Greaser	Stainless steel	DIN: X5CrNi18 10 ASTM: A 182 AISI 304 BS: 1449-2 304 S15
15	1	Chain	Zinc steel	
14	1	Chain guide	Stainless steel	
13	1	Chain handwheel	Cast iron	
12	1	Protection tube	Steel	
11	1	Cap	Plastic	
10**	1	Gasket	Nitril	
9	1	O-Ring	Nitril	
8	1	Packing gland	Aluminium DN50-450 Steel DN500-600	
7	1	Nut	Bronze	
6	1	Nut support	Zinc steel	
5*	2	Support plate	Steel + epoxy	
4	1	Stem	Stainless steel 13% Cr	
3	1	Gate	Stainless steel X5CrNi 18-10	DIN: X5CrNi18 10 ASTM: A 182 AISI 304 BS: 1449-2 304 S15
2	2	Packing	Acrylic fiber	
1	1	Body	Cast iron EN-GJL-250	DIN:GG25 ASTM: A48 class 40B BS: 1452 Grade 250
Pos.	Qty.	Description	Material	

*Pre-shaped parts up to DN300.
**Missing parts on metal / metal tightness.

DIMENSIONS

DN	A	B	C	D	ØV	H	ØK	n	ØM	Weight (kg)	
mm	inch										
50	2"	40	266	124	83	200	371	125	4	4-M16	11,5
65	2 1/2"	40	291	139	83	200	411	145	4	4-M16	12,8
80	3"	50	316	154	83	200	436	160	8	4-M16	13,4
100	4"	50	361	174	83	200	511	180	8	4-M16	15,5
125	5"	50	399	189	93	200	584	210	8	4-M16	19,4
150	6"	60	450	220	93	200	655	240	8	4-M20	22,5
200	8"	60	564	275	108	250	834	295	8	4-M20	41,8
250	10"	70	656	326	108	250	971	350	12	8-M20	54,0
300	12"	70	768	380	108	300	1153	400	12	8-M20	72,0
350	14"	96	871	438	290	300	1306	460	16	10-M20	131,0
400	16"	100	981	494	290	300	1497	515	16	10-M24	162,0
450	18"	106	1076	547	290	300	1611	565	20	14-M24	198,0
500	20"	110	1186	613	290	400	1833	620	20	14-M24	217,0
600	24"	110	1386	716	290	400	2084	725	20	14-M27	304,0

WORKING CONDITIONS

Maximum working pressure : DN 50-250 : 10 bar.
DN 300-450 : 7 bar.
DN 500-600 : 4 bar.
Maximum temperature : -10°C / +80°C (Standard tightness)

Others materials on request (if marked)	Maximum temperature	
Metal / metal	T max : -10°C / +80°C.	<input type="checkbox"/>
NBR	T max : -10°C / +80°C.	<input type="checkbox"/>
White NBR	T max : -10°C / +80°C.	<input type="checkbox"/>
EPDM	T max : -10°C / +130°C.	<input type="checkbox"/>
Silicone	T max : -10°C / +170°C.	<input type="checkbox"/>
FPM (Type Viton®)	T max : -10°C / +170°C.	<input type="checkbox"/>
PTFE	T max : +4°C / +170°C.	<input type="checkbox"/>
CSM (Type Hypalon®)	T max : +4°C / +80°C.	<input type="checkbox"/>

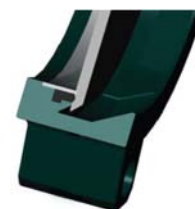
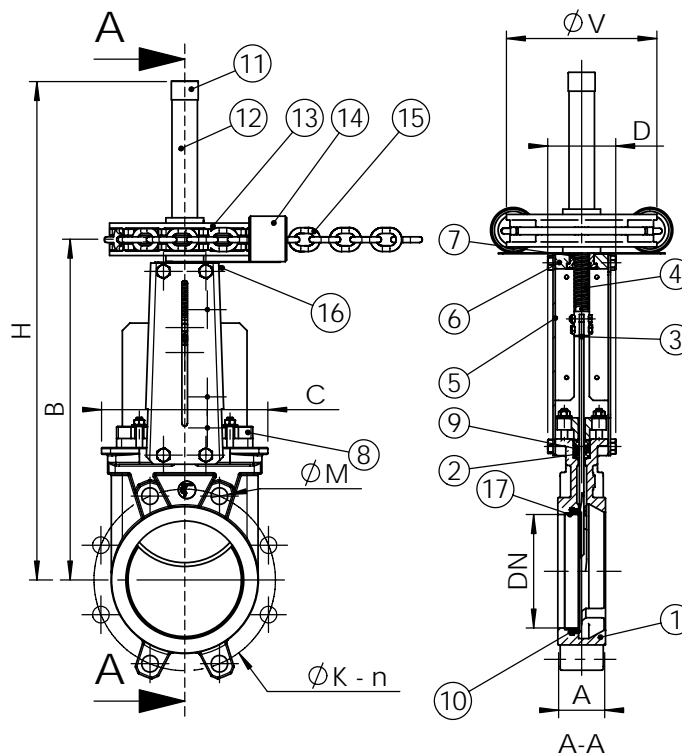
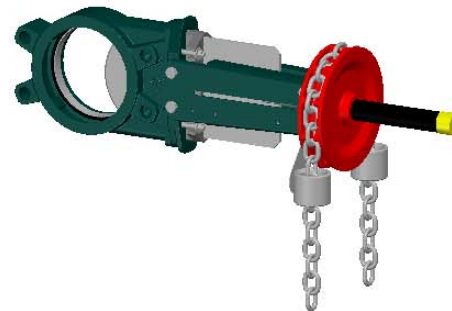

Standard tightness



Tightness metal / metal

STANDARDS

Manufacture according to the requirements of the European directive 97/23/CE «Equipments under pressure» : category III modulate H.
Test procedures are established according to standards EN 12266-1, DIN 3230, BS 5154 and ISO 5208.
Connections between flanges according to standard EN 1092-2 and DIN 2501 ISO PN10.

TECOFI France - 83, Rue Marcel Mérieux 69960 Corbas - FRANCE
Tél. +33 (0) 4 72 79 05 79 - Fax +33 (0) 4 78 90 19 19 / +33 (0) 4 72 79 05 70
Adresses e-mail : sales@tecofi.fr ; tecofi@tecofi.fr / Site web : www.tecofi.fr