

Ref. : VPE 4408-08.pas

Rev. : Initial

Date : 23/06/2016

Page : 1/1

WAFER TYPE BUTTERFLY VALVE TECLARGE WITH GEAR BOX

VPE 4408-08



APPLICATION

General use : water, sludge, etc.

GENERAL CHARACTERISTICS

Design in accordance with NF EN 593.

Tightness in both ways.

Sleeve internally reinforced in aluminium giving a low torque.

Two kinds of construction:

- wafer type with smooth ears from DN350 to DN600;
- with middle flange having smooth holes from DN700 to DN1200.

Self lubricant bearing in copper alloy.



CONSTRUCTION

11	1	Handwheel	Ductile iron
10	1	Gear box	Ductile iron
9	1	Cover	Ductile iron
8		Bushing	Copper alloy
7	1	O ring	NBR
6		Bushing	Copper alloy
5	1	Sleeve	Heat EPDM
4		Pin	Stainless steel 410
3	1	Disc	Ductile iron EN-GJS400-15
2		Stem	Stainless steel 410
1	1	Body	Ductile iron EN-GJS400-15
Pos.	Q-ty	Description	Material

DIMENSIONS

DN	A	B	C	ØD	Ø2	ISO	ØD2	ØD3	ØD4	n1-Ø1	ØD1	n-Ø	4-M	&°	J	Weight (kg)
350 14"	368	267	76,5	333,5	31,6	F14	175	140	100	4-18	460	16-23	-	22,5	8	70
400 16"	400	309	102	389,6	37,9	F14	175	140	100	4-18	515	16-28	-	22,5	10	99
450 18"	422	340	114	440,5	37,9	F14	175	140	100	4-18	565	20-28	-	18	10	119
500 20"	442	365	127	491,6	45,7	F14	175	140	100	4-18	620	20-28	-	18	14	126
600 24"	562	459	151	592,5	50,6	F16	210	165	130	4-22	725	20-31	-	18	16	226
700 28"	624	520	163	695	63,3	F25	300	254	200	8-18	840	20-31	4-M27	15	18	383
800 32"	672	591	188	794,7	63,3	F25	300	254	200	8-18	950	20-34	4-M30	15	18	488
900 36"	720	656	203	864,7	75	F25	300	254	200	8-18	1050	24-34	4-M30	12,85	20	651
1000 40"	800	722	216	965	85	F25	300	254	200	8-18	1160	24-37	4-M33	12,85	22	840
1200 48"	941	864	276	1160,6	105	F30	350	298	230	8-22	1380	28-41	4-M36	11,25	28	1229

WORKING CONDITIONS

Maximum working pressure : 10 bar.

Maximum working temperature : -15 °C / +130 °C.

Peak temperature : -30°C / + 150°C

STANDARDS

Manufacture according to the requirements of the European directive 2014/68/UE «Equipments under pressure» : modulate H. Pressure test according to standards EN 12266-1, DIN 3230, BS 5154 and ISO 5208 :

Body : 15 bar.

Seat : 11 bar.

Face to face according to standard EN 558-1 serie 20, ISO 5752 serie 20 and DIN 3202.

Wafer type ISO PN10 connections according to standard EN 1092-2.

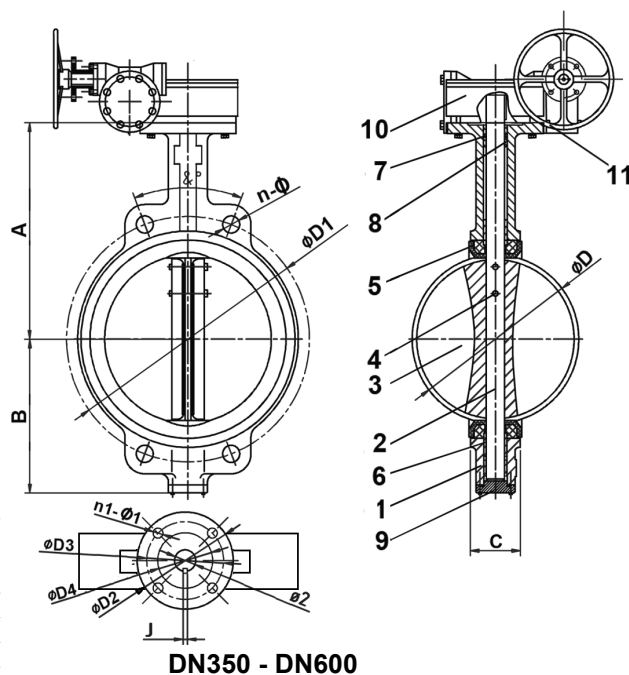

DN350 - DN600

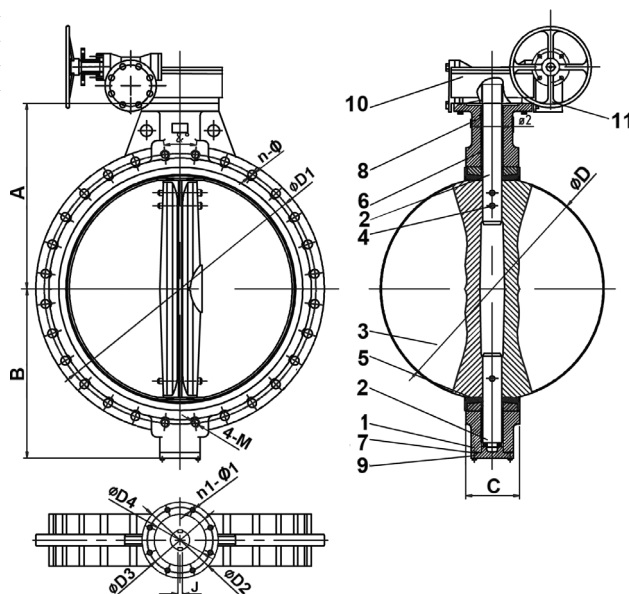

DN700 - DN1200

TECOFI France - 83, Rue Marcel Mérieux 69960 Corbas - FRANCE
Tél. +33 (0) 4 72 79 05 79 - Fax +33 (0) 4 78 90 19 19 / +33 (0) 4 72 79 05 70
Adresses e-mail : sales@tecofi.fr ; tecofi@tecofi.fr / Site web : www.tecofi.fr