

Ref. : VPE 3448 pas

Rev. : A

Date : 23/01/2017

Page : 1/1

BUTTERFLY VALVE WITH HANDLE

VPE 3448-02



APPLICATION

General use : water, air, acids, etc.
"Non suitable for steam application"

GENERAL CHARACTERISTICS

Design according with EN 593.
Tightness in both ways. Wafer type with smooth ears.
Flexible sleeve adapted to the shape of the body assures low operating torque. High and low semi stem giving a high flow coefficient, machined disc on periphery giving a low and regular torque. Unejectable stem, mounting flange according to ISO 5211.

CONSTRUCTION

15	2	Washer	Stainless steel 201
14	2	Nut	Stainless steel 201
13	2	Screw	Stainless steel 201
12	1	Handle	Ductile iron
11	1	Lower shaft	Stainless steel 420
10	1	Disc	Chromed ductile iron
9	1	Sleeve	Heat EPDM
8	2	Long bushing	Fiber glass + PTFE
7	1	Upper shaft	Stainless steel 420
6	2	Bushing	Fiber glass + PTFE
5	1	O ring	NBR
4	1	Ring	Stainless steel 201
3	1	Collar	65Mn
2	1	Body	Cast iron EN-GJL250
1	1	Antidust	NBR
Pos.	Q-ty	Description	Material

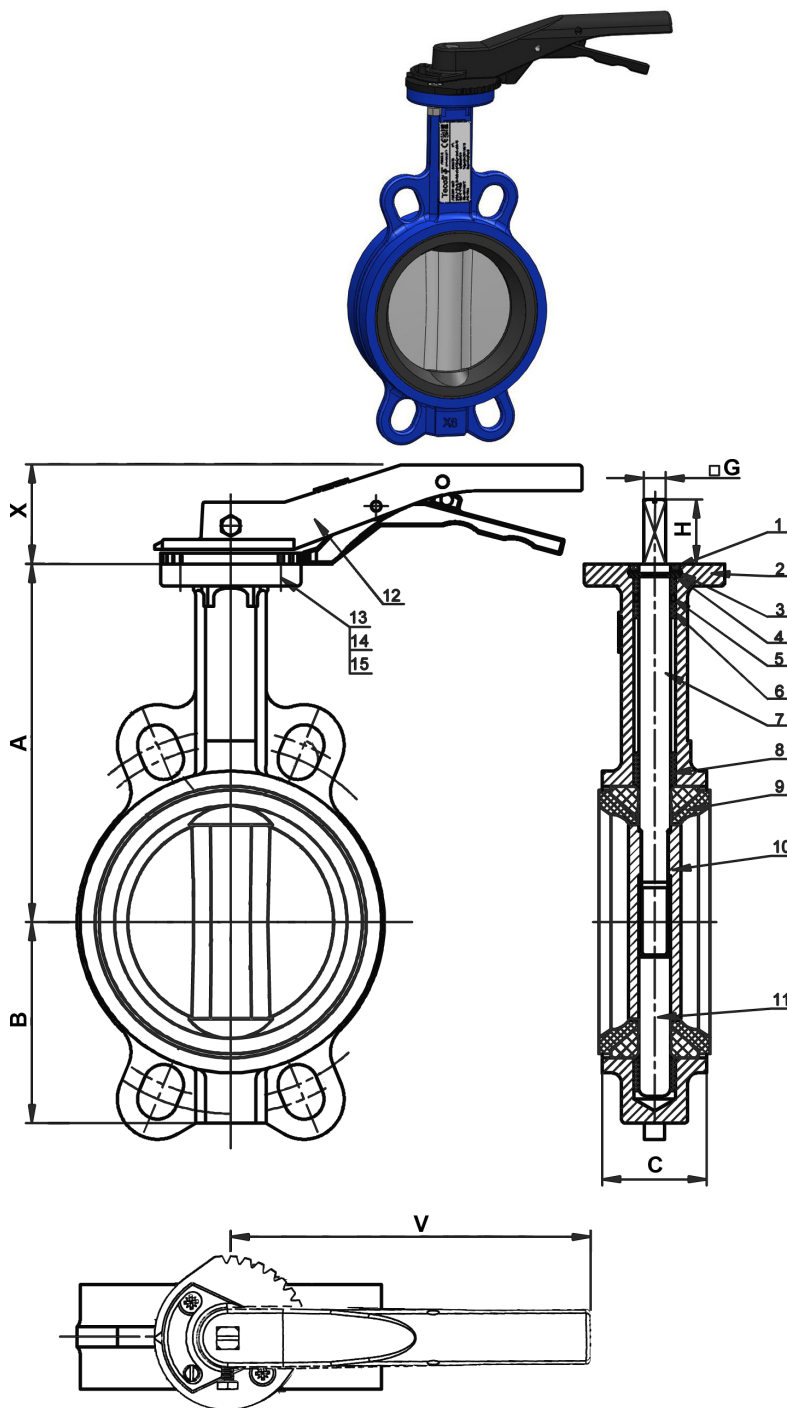

DIMENSIONS

DN		A	B	C	X	H	G	V	Weight (kg)
mm	inch								
40	1"1/2	134	58	33	53	32	9	180	2,1
50	2"	140	65	42	53	32	9	180	2,6
65	2"1/2	152	73	45	53	32	9	180	3,0
80	3"	159	89	45,2	53	32	9	180	3,5
100	4"	178	100	52	53	32	11	180	4,4
125	5"	191	115	54,5	58	32	11	220	6,5
150	6"	203	130	54,5	58	32	14	220	7,8

WORKING CONDITIONS

Maximum working pressure : 16 bar.
Maximum working temperature : -15°C / +130°C.
Peak temperature: -30°C / +150°C

STANDARDS

Manufacture according to the requirements of the European directive 2014/68/UE «Equipment under pressure»: modulate H.
Face to face according to standards NF EN 558-1 serie 20, ISO 5272 série 20, DIN 3202.
Mounting between flanges PN 10 / PN 16: according to EN 1092-2, BS 450, ANSI B16.1-5.
Adjustable between flanges ASME B16.5 Class 150 and JIS 10K; GOST PN10/16.
Pressure test according to standards EN 12266-1, DIN 3230, BS 6755 and ISO 5208 :
Corps: 24 bar
Siège: 17.6 bar

TECOFI France - 83, Rue Marcel Mérieux 69960 Corbas - France
Tél. +33 (0)4 72 79 05 79 - Fax +33 (0)4 78 90 19 19 / +33 (0)4 72 79 05 79
Adresses e-mail: sales@tecofi.fr; tecofi@tecofi.fr / site web: www.tecofi.fr