

Ref. : BS 5379.pas

Rev. : Initial

Date : 25/10/06

Page : 1/1

3 PIECES FULL BORE BALL VALVE PN64

BS 5379



Tecofi
FAREX FLUID SOLUTION DESIGNER

APPLICATION

General uses : All chemical fluid, liquid steam, gas, etc.

GENERAL CHARACTERISTICS

3 pieces steel, stainless steel stem and ball - PTFE seat.
BSP threaded ends - Full bore.
Operating by stainless steel 304 lever with locking devise - PN 64.

CONSTRUCTION

9	1	Nut packing	A351 CF8M	
8	1	Packing	PTFE	
7	1	Ball	Stainless steel 316 X5CrNiMo 17-12-2	DIN: X5CrNiMo18 10 ASTM: A 182 AISI 316 BS: 970 316 S16
6	1	Handle	Z7 CN 18-09	
5	2	Body gasket	PTFE	
4	2	Seat	PTFE	
3	1	Stem	Stainless steel 316 X5CrNiMo 17-12-2	DIN: X5CrNiMo18 10 ASTM: A 182 AISI 316 BS: 970 316 S16
2	2	Ends	Carbon steel	DIN: GS-C25 ASTM: A216 Grade WCB BS: 161 Grade 430E
1	1	Body	Carbon steel	DIN: GS-C25 ASTM: A216 Grade WCB BS: 161 Grade 430E
Pos.	Qty.	Description	Material	

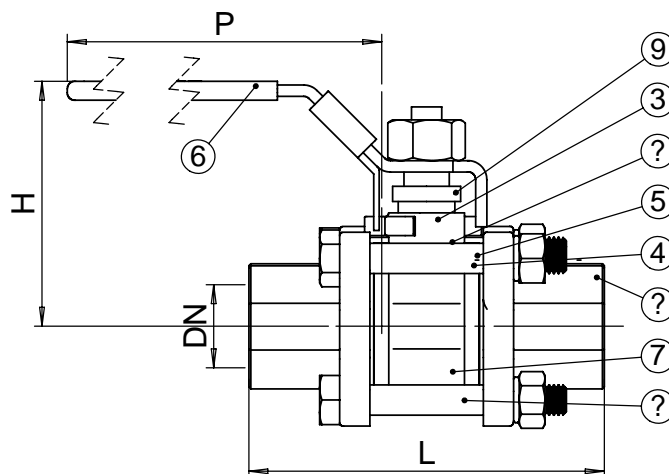
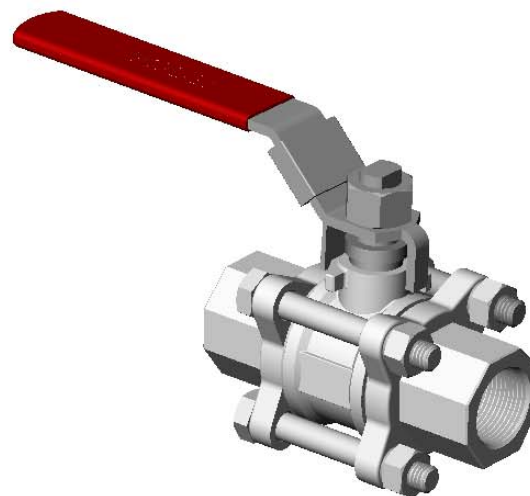

DIMENSIONS

DN		L	H	P	S	T	Weight (kg)
mm	inch						
8	1/4"	59,0	52	108	14	14,1	0,26
12	3/8"	60,0	52	108	17,5	17,5	0,24
15	1/2"	65,5	63	113	22	21,7	0,34
20	3/4"	76,5	68	113	27,5	27,1	0,59
25	1"	86,2	79	135	34	33,8	0,87
32	1" 1/4	103,1	88	135	43	42,5	1,29
40	1" 1/2	118,0	97	160	49	48,7	2,06
50	2"	131,5	108	160	61	61,1	3,35

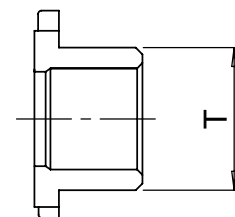
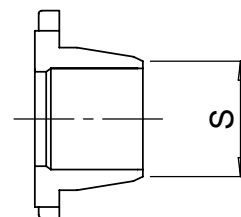

Socket Welding

Butt Welding

WORKING CONDITIONS

PS max : 64 bar (TS max : + 100°C)

Steam :
PS max : 10 bar (TS max : + 180°C)

Pressure test according to standards
EN 12266-1, DIN 3230, BS 5154 and ISO 5208.
Body : 96 bar
Seat : 70 bar

STANDARDS

Ends connections :
BSP threaded according to standard ISO 228-1,
butt welding or socket welding.

TECOFI France - 83, Rue Marcel Mérieux 69960 Corbas - FRANCE
Tél. +33 (0) 4 72 79 05 79 - Fax +33 (0) 4 78 90 19 19 / +33 (0) 4 72 79 05 70
Adresses e-mail : sales@tecofi.fr ; tecofi@tecofi.fr / Site web : www.tecofi.fr